

**SIDE ELEVATION**

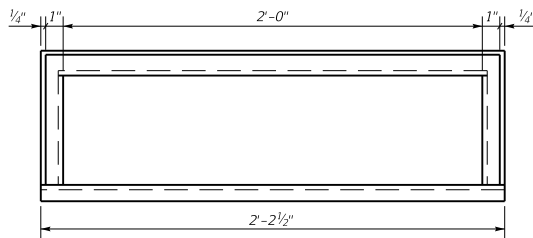

**FRONT ELEVATION**

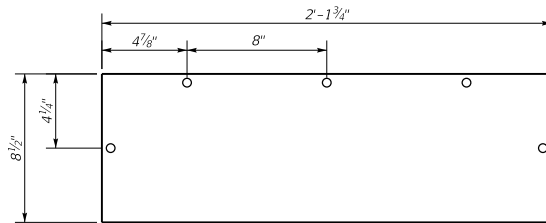

**COVER PLATE**

Mount box flush with barrier face.  
Bottom of box will slope approximately  
1/4" per foot to drain when properly installed.

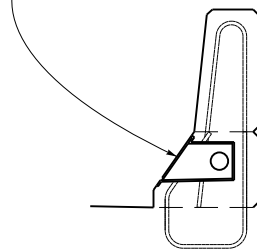

**TYPICAL INSTALLATION  
IN TYPE 3 BARRIER**

## General Notes

Construct junction boxes from 1/4" A36 steel plate and the junction box cover from 1/8" A36 plate. Hot dip galvanize box and cover after fabrication and in accordance with ASTM A123 and the Standard Specifications. Cover plate shall include (5) Stainless Steel screw taps with wing nuts and a Rubber Gasket for all sides where screws are installed.

Fittings shall be UL listed and CSA-certified concrete tight on the outside of the Junction Box conduit connection. Use a sealing lock nut and a rigid PVC conduit bushing on the inside for all conduit penetrations.

Liberalily coat the threads of the cover fasteners with anti-seize compound during construction and before final closure.

Protect cover of J.B. from damage/disfigurement from masonry coating application and other sources by taping or wrapping during construction. Remove protection prior to final electrical inspection and repair any damage or disfigurement to the satisfaction of the Engineer and at no cost to the Department.

When properly installed, box cover will be flush with barrier face and box bottom will slope to drain approximate 1/4" / ft. in all cases.

The price bid for Junction Box - 24" shall include all costs to furnish and install the junction box in accordance with these plans and the Specifications.

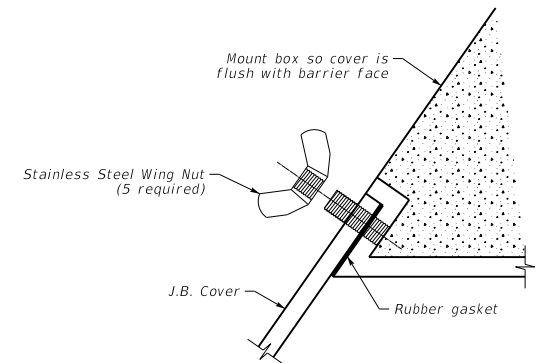

**DETAIL "A"**

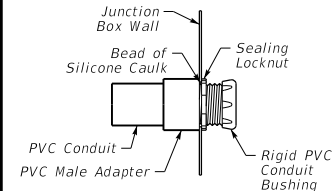

**BUSHING DETAIL AT  
J.B. CONDUIT ENTRY**

KENTUCKY  
DEPARTMENT OF HIGHWAYS

24 INCH JUNCTION BOX  
TYPE 3 BARRIER

STANDARD DRAWING NO. BGX-020

SUBMITTED: *Bob Adams* 02-26-20  
DIRECTOR DIVISION OF STRUCTURAL DESIGN DATE

APPROVED: *[Signature]* 02-26-20  
STATE ELECTRICAL ENGINEER DATE